

F. P. BARNEY,

MACHINE FOR MAKING CHAIN LINKS FROM COILED WIRE.

No. 283,556.

Patented Aug. 21, 1883.

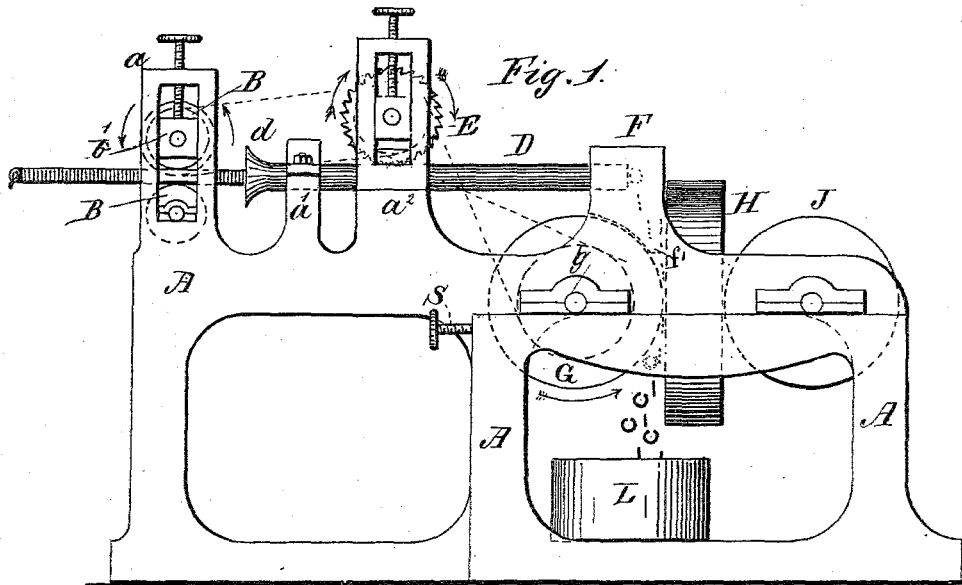
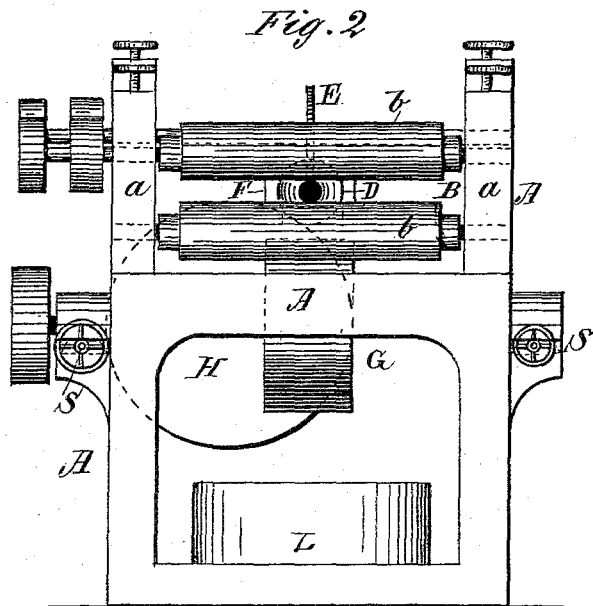

Witnesses.  
 H. A. Daniels  
 William S. Fowler.

Inventor  
 Frank P. Barney  
 per Henry M. [Signature]

F. P. BARNEY.

MACHINE FOR MAKING CHAIN LINKS FROM COILED WIRE.

No. 283,556.

Patented Aug. 21, 1883.

Fig. 3.

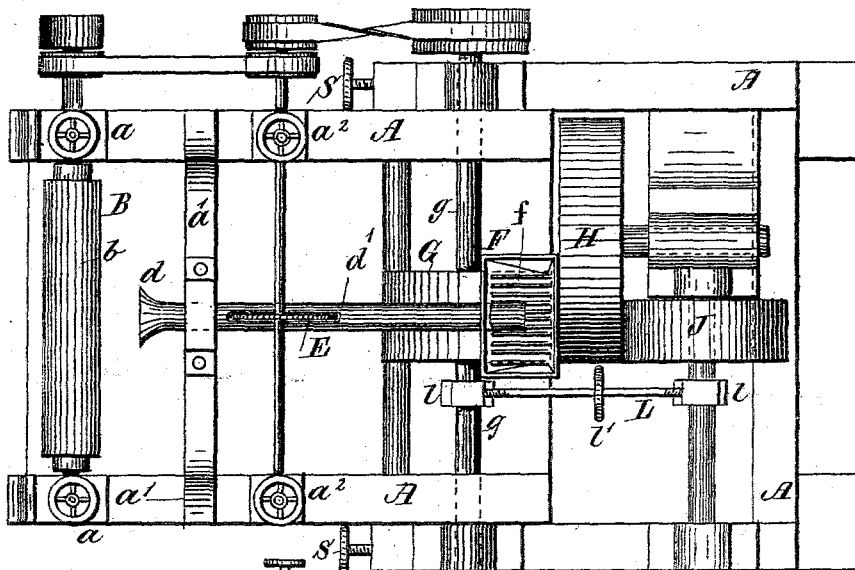
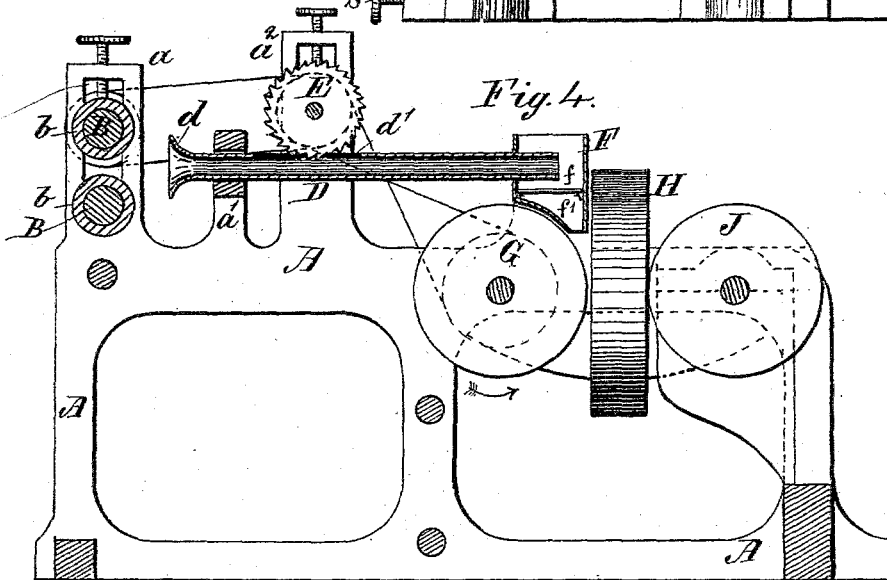

Fig. 4.



Witnesses  
 H. A. Daniels  
 William S. Butler

Inventor  
 Frank P. Barney  
 by Henry O. Th... atty

# UNITED STATES PATENT OFFICE.

FRANK P. BARNEY, OF NORTON, MASSACHUSETTS.

## MACHINE FOR MAKING CHAIN-LINKS FROM COILED WIRE.

SPECIFICATION forming part of Letters Patent No. 283,556, dated August 21, 1883.

Application filed November 8, 1882. (No model.)

*To all whom it may concern:*

Be it known that I, FRANK P. BARNEY, a citizen of the United States, residing at Norton, in the county of Bristol and State of Massachusetts, have invented certain new and useful Improvements in Machines for Making Chain-Links from Coiled Wire; and I do hereby declare the following to be a full, clear, and exact description of the invention, such as will enable others skilled in the art to which it appertains to make and use the same, reference being had to the accompanying drawings, and to letters or figures of reference marked thereon, which form a part of this specification.

This invention relates to the manufacture of chain-links from wire coils; and in order that my improvements and their advantages may be better understood I will briefly describe the manner in which such links have heretofore been made.

In the manufacture of links for watch and other chains from gold or gold-plated wire, in which the links, whether oval or cylindrical, are flattened, it has been the custom to take, for cylindrical links, a coil of wire about twelve inches long and slip the same upon a mandrel about fifteen inches long and of the same diameter as the interior diameter of the coil. This mandrel, with its coil of wire, is then pulled through a guide in a lathe-rest in the path of a burr or small saw set low enough to cut the coils in a line parallel to the axis of the mandrel or coil, and when all the coils are cut the links are removed, to be thereafter flattened. The flattening of the links is effected between two dies, one of which is the bed die or plate, while the other has a vertical reciprocating movement, and acts as a hammer, it being lifted and then allowed to fall upon a few links spread upon the bed-plate. In throwing the links upon the bed-plate they often cross each other or lie one upon another, and the hammer striking them not only defaces the links, but forces them out of shape and they are unfit for use. This practice results in serious losses, as the most expert flatteners cannot always spread the links so as to separate all the links from one another, especially if he desires to perform a good day's work. To do this work of flattening the links requires a skilled operative to avoid too great a loss in

spoiled links, and, besides this, it is very slow and very tedious, and an expert workman cannot burr or cut and stamp more than eight pounds of links in a day of ten hours' labor. In making oval links, the coils, as they are wound, are all twisted, or what is technically termed "corkscrew-shaped," as described in an application for patent for process of and appliances for coiling wire, of even date with this. These coils are cut up into lengths of about twelve inches, annealed, forced upon a gage about fifteen inches long to bring them back to their proper shape, and then sawed or burred and flattened or not, as above described. Serious losses occur here in the process of annealing in order to render the coil sufficiently pliable to take out the twist by forcing it upon a gage or mandrel of the shape and diameter the coil should have, and the operation is a very slow and laborious one.

The object of this invention is to remedy the difficulties enumerated, avoid the losses incurred by the old methods of manufacturing chain-links, and to considerably increase the percentage of work done in a given time.

In carrying out my invention any suitable device may be employed for cutting the links from a continuous coil of from forty to fifty or more feet in length, or for cutting and simultaneously flattening such links, neither of which has ever been used, either singly or combined, and for the reason that continuous perfect cylindrical or oval coils could not heretofore be produced by the means available for the purpose of coiling. For instance, the continuous coil may be fed through a tubular guide over or under a rotating cutter, or such coil may be fed over a cylindrical guide over or under such cutter, and the links, when cut, may be flattened by concussion, or the flattening may be effected by compression. The feeding devices to feed the coil along the path of the cutter may also be of any desired or approved construction or operation—as, for instance, two superposed grooved rolls may be employed to feed the coil, or cylindrical rolls may be employed for that purpose. After long experiments with all these various devices I have found that the best results are obtained by using a yielding feeding device, as experience has proved that feeding devices having hard

surfaces deface or mar the wire coil passing through or fed along by them to such an extent as to render portions of it valueless for use as chain-links. I have further found that  
 5 a tubular guide through which the coil is fed to and within which the links are cut by the cutter has given better results than any other guide experimented with; also, that, using a saw or burr, better results are obtained than  
 10 by the use of other species of cutters, and for the reason that a burr can be rotated at such a speed as to cut the links as fast as the coil can be fed thereto. I have further found that the flattening of the links, when effected by  
 15 compression between two movable surfaces, results in no loss of spoiled links, which is the case when the compression is effected between stationary surfaces, or when the links are flattened by concussion, whether a rattler or  
 20 spreader is used in conjunction with such devices or not.

In the accompanying drawings I have shown a machine for cutting and flattening chain-links, or for cutting chain-links from continuous wire coils, whereby the cutting and flattening are effected in a neat and very expeditious manner, and without any loss, either through the spoiling of the wire by the feeding device or through the action of the flattening devices.

In the drawings, Figure 1 is a side elevation, Fig. 2 an end elevation, Fig. 3 a plan view, and Fig. 4 a longitudinal section, of the machine.

35 Like letters of reference are employed to indicate like parts wherever such may occur.

A is the main frame, constructed of any suitable material, and of appropriate form to support the operating mechanism.

40 B B indicate a pair of feed-rolls, between which the wire coil is passed, and by which it is fed to the saw or burr, said rolls being covered with any suitable flexible material—such as cloth, felt, or other like material—though  
 45 I prefer to use a rubber cover, *b*, as I have found that this material has no effect whatever to mar the polish of the wire, and is of great importance for that reason. The rolls are mounted in standards *a*, projecting from the  
 50 frame, and in rear of said standards is mounted a tubular guide, D, supported at or near its front end in a standard, *a'*, and at the rear end by a rattler or spreader hopper, F, as plainly shown in Figs. 3 and 4.

55 The guide D consists of a metal tube, of the required interior diameter and shape to allow the cylindrical or oval coil to pass through, and has a flaring mouth, *d*, to facilitate the introduction of the end of the coil in starting  
 60 the operation.

Above the tube D, in standards *a*<sup>2</sup>, is mounted a burr, E, in such a position that its teeth will project through a slot, *d'*, formed for the purpose in the guide-tube, sufficiently far to  
 65 cut the coil into links as it passes through the tube.

The burr is rotated in a direction the reverse of that of the feed, as shown by the arrows; the coil being thus made to act as a resistance, the cut links being crowded or  
 70 pushed toward the rear end of the tube, from which they fall into a hopper, F, that is or may be provided with cross-bars *f*, that serve to spread the links, said hopper acting as a rattler or spreader.

75 The discharge end *f'* of the hopper is of the same diameter transversely as that of one of the flattening or compressing wheels G, which is mounted immediately below the tube D and hopper F, as shown. The links as they fall  
 80 from the discharge-mouth of the hopper pass between the periphery of the flattener or compressing-disk wheel G and the face of a larger or main compressing-disk wheel, H, between which the links are flattened, and from which  
 85 they fall, ready for use, into a receiver, L. As the pressure exerted by the large disk-wheel is upon one side of its axis, this would tend to strain its shaft in its bearings, to avoid which I employ a bearing-disk wheel, J, that bears upon  
 90 the opposite side of the face of the wheel H, as shown. To further solidify these parts and prevent end-thrust or backlash, I connect the shaft of the bearing-disk wheel J with that of the compressing-disk wheel G by means of  
 95 a rod, L, having on one end a right and on the other a left hand screw-thread, said rod being connected with sleeves *l*, secured to the shaft, in which sleeves the rod operates to move the  
 100 shaft *g* of disk G away from or toward the wheel H. The rod L carries a hand-wheel, *l'*, for operating the same.

In the manufacture of chain-links from coiled wire, coils of various diameters and thickness of wire have to be cut, or cut and  
 105 flattened, whether these are cylindrical or oval in cross-section, to suit the size of chain-link required.

To enable the machine to cut, or to cut and flatten, links of all sizes and thicknesses, the  
 110 parts must be so arranged as to accommodate themselves to the altered circumstances. For this reason I make the feed-rolls, saw, and compressing-disk wheel G, adjustable in their bearings.

115 The adjustment of the feed-rolls is effected by the bearing-block *b'* of the upper roll, made adjustable in the standards *a* of the frame. The saw or burr is likewise made adjustable vertically, as shown, and the compressing-disk  
 120 wheel G is made adjustable longitudinally toward or from the disk-wheel H.

The shaft *g* of the disk-wheel G is mounted in bearings sliding in ways formed in the frame A, and is adjustable by means of set-screws  
 125 S. I do not of course limit myself to the means described and shown for adjusting the feed-rolls, burr, and compressing disk or disks, as many other well-known and equally effective means may be employed for this purpose.

130 The various parts of the machine may be driven by any suitable arrangement of belting

or gearing. I have shown the feed-rolls driven from the burr-shaft and the latter shaft by cross-belt from the compressing-disk-wheel shaft *g*, and the latter shaft is rotated from any suitable prime motor, the compressing-disk wheel *H* and bearing-wheel *J* being rotated by friction.

I prefer to rotate both the compressing-disk wheels, and this may be readily effected by any mechanic versed in the art of gearing driving mechanism. For instance, two counter-shafts, located transversely of the machine above the operating parts, may be belted together and driven from any suitable prime motor. One of these shafts may carry two pulleys to drive the compressing-disk wheels, and the other shaft may carry two pulleys to drive the burr and feed rolls.

Toothed gearing may be employed to drive the various parts, or any other system or arrangement of belting, as may be found most convenient, as I do not wish to limit myself to any particular arrangement of driving mechanism. With such a machine an ordinary laborer can cut and flatten one hundred and fifty pounds of coiled wire in an average day's work.

In my application for patent hereinabove referred to I have described a cylindrical receiver for the reception and coiling of the wire as it is spun off the peg. When the coil is cut, the receiver is removed and another receiver placed in position to receive the coiled wire. The end of the cut coiled wire is now passed between the feed-rolls and into the guide, and while the coil is cut into links, or cut into links and the links flattened, the coil is again ready to be cut at the coiling-machine, and so on, so that one man (who need not be a skilled artisan, as will be readily understood, as the machines perform all the labor for which skill is required) is enabled to attend to both machines, and can, in a day of ten hours' labor, coil one hundred and fifty pounds of wire and cut the coils into links and flatten the latter, while a skilled artisan, by the methods heretofore employed, will only work up, by hard work, between ten and fifteen pounds of wire.

From what has been said the advantages of my improved processes and machines will be readily understood.

Having now described my invention, what I claim is—

1. In a machine for cutting continuous lengths of wire coil into links, the combina-

tion, with the cutting appliances and a guide to guide the coils thereto, of a pair of elastic feed-rolls, whereby the coil is fed to the guide and cutting appliances, as described.

2. In a machine for cutting continuous lengths of wire coil made from wire plated with or made of precious metal, the combination, with the cutting appliances, of a pair of rubber-covered feed-rolls, substantially as and for the purposes specified.

3. In a machine for cutting continuous lengths of wire coil, a pair of feed-rolls, a tubular slotted guide, and a saw or burr, combined for co-operation substantially as and for the purposes specified.

4. The combination, with the burr or saw *E*, of the tubular slotted guide *D*, having a flaring mouth, and the rubber-covered feed-rolls, *B*, substantially as and for the purpose specified.

5. The combination, with the guide-tube *D*, of a pair of rubber-covered feed-rolls, one of which is adjustable vertically in its bearings relatively to said guide-tube, and a burr or saw, *E*, also adjustable vertically and relatively to said guide-tube, as and for the purpose specified.

6. In a machine for cutting continuous lengths of coiled wire into links and flattening such links as they are cut, the combination, with the guide and burr *E*, of appliances to compress and flatten the links as they fall from the guide, substantially as described.

7. The combination, with the guide-tube, of the disk-wheels *G H*, operating substantially as described.

8. The combination, with the guide-tube and disk-wheels *G H*, of the hopper *F*, substantially as and for the purpose specified.

9. The combination, with the burr *E*, guide-tube *D*, and disk-wheels *G H*, of the hopper *F*, having spreader-bars *f*, substantially as and for the purpose specified.

10. The combination, with the disk-wheel *H*, of the adjustable wheel *G* and bearing-wheel *J*, the shafts of which are adjustably connected by collars and rod *L*, substantially as and for the purposes specified.

In testimony whereof I affix my signature in presence of two witnesses.

FRANK P. BARNEY.

Witnesses:

BENJ. L. WOOD,  
ELISHA T. JACKSON.